

# modular

Laboratory Benchtops Made of Technical Ceramics



Details of our products are based on the results of extensive development and the associated test findings. Many years of experience in the most varied fields of application provide an additional guarantee for the durability of FRIDURIT Technical Ceramics. However, the user remains responsible for verifying our information and recommendations on the basis of his individual requirements and, if necessary, for confirming suitability of the product for his application by means of independent tests.

Our technical specifications are based on DIN 12915 and EN 14879-6.

We reserve the right to make technical changes.



<b>Introduction</b>	
Preface	4
Quality in the Laboratory	5
Perfection with FRIDURIT	5
FRIDURIT Technical Ceramics	6
<b>Laboratory Benchtops</b>	
FRIDURIT modular Laboratory Benchtops	7
Adjustment to Structural Conditions	8
Glaze Colours	9
<b>Laboratory Sinks</b>	
Sinks	10
Cup Sinks - Oval	11
Cup Sinks - Round	12
P-Trap	13
<b>Technology</b>	
Cutting Signs	14
Edge Profiles	15
Apertures and Bores	15
Edge Cutouts	15
<b>Mounting Instructions for Benchtops</b>	
Mounting	16
Joint Sealing	16
<b>Mounting Instructions for Laboratory Sinks</b>	
Installation Options	17
<b>General Product Information</b>	18
<b>Material Properties</b>	19



Figure 1)  
Chemical laboratory



Figure 2)  
Pharmaceutical laboratory

## Preface

As a designer, laboratory builder or user of a laboratory environment you are interested in learning more about full-size benchtops made of Technical Ceramics (chemical-technical stoneware in accordance with EN 14879-6). This technical description provides you with comprehensive information on FRIDURIT modular laboratory benchtops made of Technical Ceramics. Should you however have any questions that remain unanswered in this description we will be happy to hear from you. Please find our contact details at the end of this brochure.

This technical description together with further documents such as specifications and certificates are available in electronic form at [www.friatec.de](http://www.friatec.de).

## Quality in the Laboratory

Quality demands set by modern laboratories increase side by side with the requirements and standards to which products and services are subjected. This applies to the same degree to the environment in which tests, analyses and experiments are carried out. This is where laboratory work surfaces make a substantial contribution if they can be kept intact, clean and in a hygienic condition. Such laboratory environments support high-quality work processes, or even create in the first place the basic conditions necessary for this. It thus follows that the condition of laboratory work surfaces is decisive for the impression made by the laboratory as a whole.

## Perfection with FRIDURIT

FRIDURIT full-size laboratory benchtops and sinks made of Technical Ceramics have been used for many years in a wide variety of laboratory applications. With its pore-free surface FRIDURIT Technical Ceramics offers a unique combination of chemical resistance, scratch resistance and thermal stability. This property profile makes it possible to maintain permanently the perfect working environment. Even after many years of intensive use FRIDURIT laboratory benchtops still look just like new.

FRIDURIT modular laboratory benchtops offer all the advantages of a ceramic work surface at a highly attractive price. They are 20 mm thick and are designed without ceramic marine edges. Each benchtop is manufactured to the required dimensions and is supplied ready for mounting. All worktops are self-supporting and require no additional sub-structure so that they can be mounted directly onto the base unit. Four-point support is sufficient.

FRIDURIT laboratory sinks made of Technical Ceramics can be integrated just where access to water is required.

Choose from a wide range of glaze colours and plan your work surface exactly in line with your own requirements.

Our experience in manufacturing ceramic benchtops and sinks is your guarantee for highest quality combined with flexible design.



Figure 3)  
Island bench



Figure 4)  
Wall bench

## FRIDURIT Technical Ceramics

Work surfaces in the laboratory are exposed to extreme stresses. FRIDURIT Technical Ceramics products are tuned optimally to the work processes in your laboratory and withstand all strains and stresses. FRIDURIT laboratory benchtops and sinks stay just like new, even when permanently subjected to chemicals and extreme thermal or mechanical stresses such as scratching, scouring and cleaning processes.

## Technical Ceramics - Natural material of a very special kind:

### ■ easy to clean

FRIDURIT laboratory benchtops made of Technical Ceramics pose no problems in terms of cleaning. Whether soiled by dyes, varnishes, dirt or grease - they can all be removed without trace. Thanks to their extreme hardness and abrasion resistance our Technical Ceramics products remain totally unaffected, even after undergoing repeated cleaning with aggressive cleaning agents and tools.

### ■ resistant to chemicals

FRIDURIT Technical Ceramics products are fully resistant to solvents and chemicals commonly used in the laboratory, e.g. aqua regia, hydrochloric acid, sulphuric acid, nitric acid and sodium hydroxide, even when used at high concentrations and temperatures and with a long reaction time.

### ■ microbiologically pure

FRIDURIT laboratory benchtops can be decontaminated and disinfected. Their permanently sealed surfaces preclude breeding grounds for viruses, bacteria or germs.

### ■ scratch resistant

FRIDURIT laboratory benchtops always look as good as new. Their extremely high scratch-resistance (Mohs Hardness Scale 7) prevents all trace of use.

### ■ heat resistant

FRIDURIT Technical Ceramics is resistant to heat from open flames and hot objects up to temperatures of 500 degrees Celsius. It is non-flammable and completely fire-proof.

### ■ environmentally compatible

FRIDURIT Technical Ceramics is manufactured purely and simply from natural earth resources, such as clay, kaolin and feldspar. Such material, which contains no chemical substances, poses no problems in terms of recycling. FRIDURIT Technical Ceramics is thus a classic example of "green" building materials, which represent an important element in implementing "Green Building" concepts. These concepts (e.g. LEED, BREEAM) increase resource efficiency in buildings while at the same time reducing damaging effects on both health and the environment. Laboratory staff are thus active in a working environment that is free of emissions and thoroughly safe. FRIDURIT Technical Ceramics is non-flammable (Euroclass A1) and does not increase the fire load of buildings.

The FRIDURIT Technical Ceramics manufacturing process takes place in accordance with ISO standards for general process management (ISO 9001) as well those regarding adherence to environmental aspects (ISO 14001). Sustained development and viability is the maxim for using FRIDURIT Laboratory Technology. This is why we are also a member of EGNATON – The European Association for Sustainable Laboratory Technologies.

We will be happy to provide you further information on this material.

## FRIDURIT modular Laboratory Benchtops

FRIDURIT modular laboratory benchtops can be combined to wall-fitted laboratory workplaces or to free-standing island bench units. The maximum dimensions of a worktop are 900 x 1800 mm. Within this maximum range individual worktop dimensions can be selected freely. Appropriate adjustments to the substructure fittings result in an attractive joint finish. The circumferential marine edge means that a closed benchtop arrangement of any length is possible. Benchtop arrangements in combination with other materials can also be implemented according to your individual requirements.

Laboratory sinks can be integrated just where they are needed. They can be top-mounted or flush-mounted.



Figure 5)  
Example of an island bench

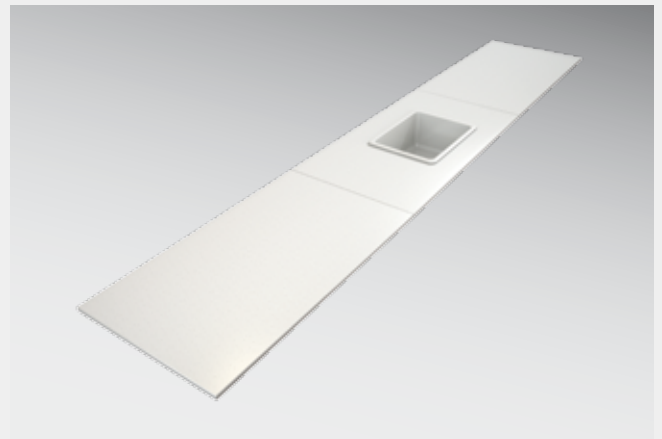

Figure 6)  
Example of a wall bench solution

## Adjustment to Structural Conditions

We will adjust your worktops to the existing structural conditions. Edge cutouts for pipes, struts and supports can be planned in.

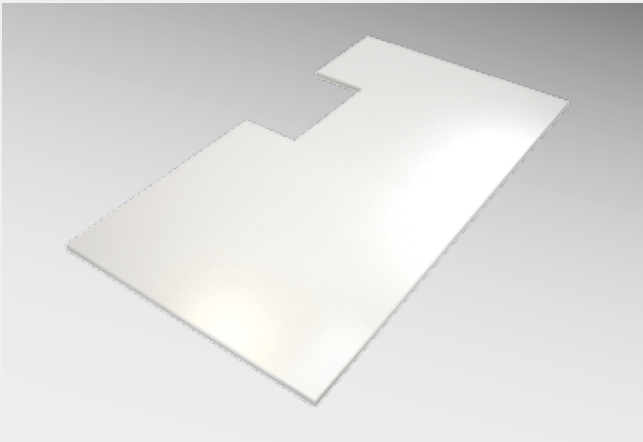

Figure 7)  
Benchtop with rectangular edge cutout

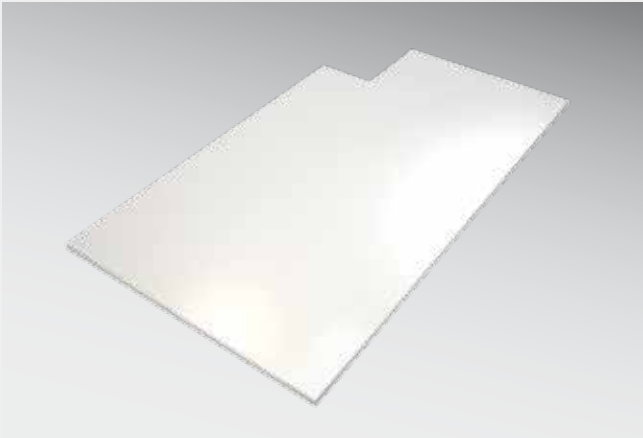

Figure 8)  
Benchtop with rectangular edge cutout

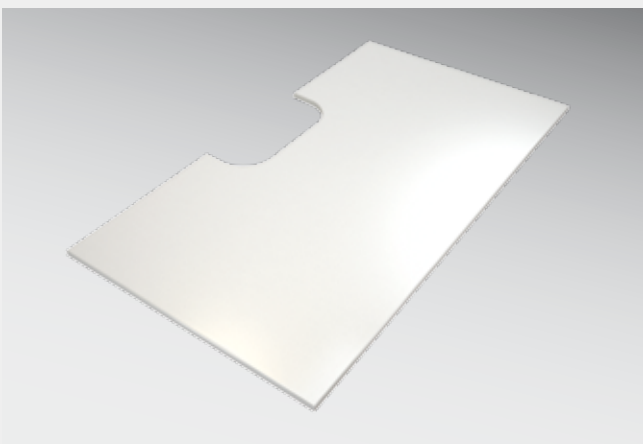

Figure 9)  
Benchtop with round edge cutout

## Glaze Colours

A wide range of glaze colours as well as the option of selecting special colours make FRIDURIT laboratory benchtops and sinks made of Technical Ceramics products that satisfy the very highest demands both ergonomically and aesthetically. Figure 10 shows a selection of glaze colours available. Laboratory benchtops and sinks are available in plain colour glazing. The benchtops also come in black-speckled glazing.

We will be pleased to send you ceramic colour samples upon request.

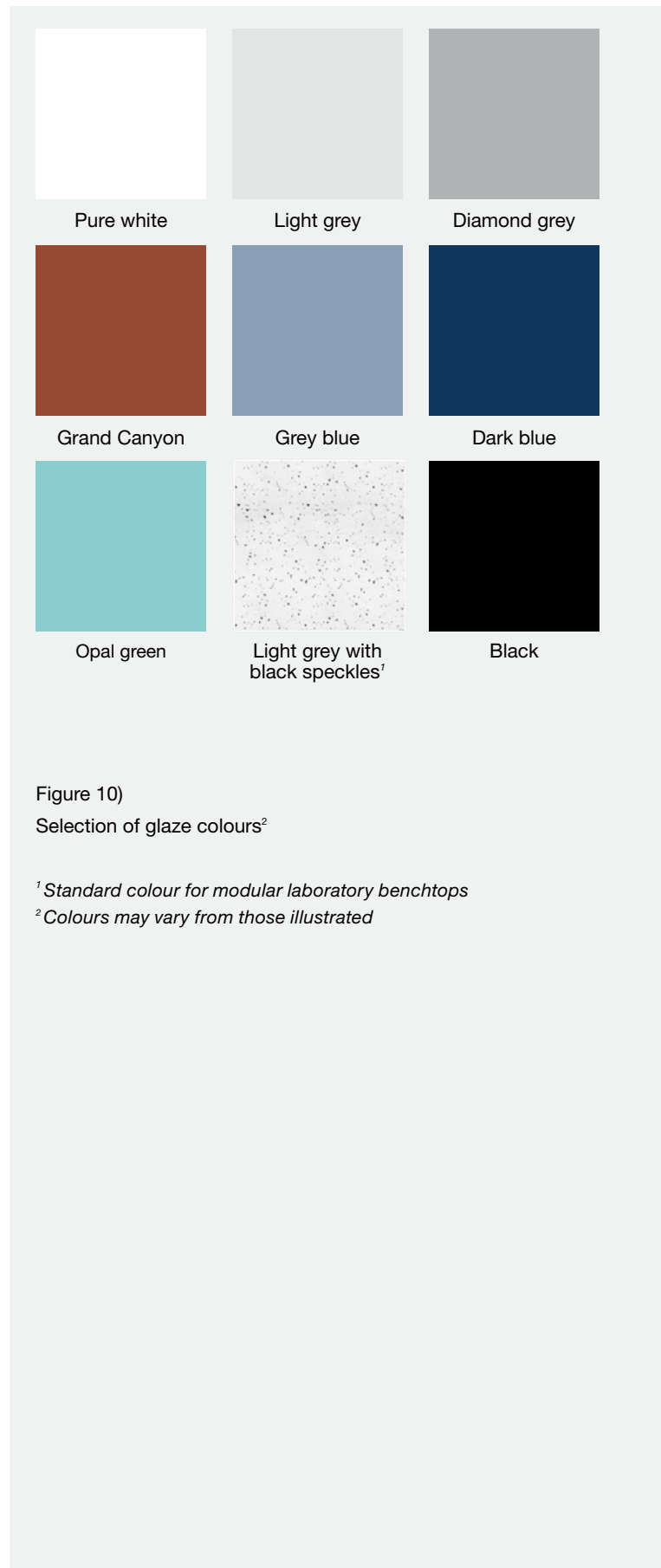

Figure 10)  
Selection of glaze colours<sup>2</sup>

<sup>1</sup> Standard colour for modular laboratory benchtops

<sup>2</sup> Colours may vary from those illustrated



### Sinks

FRIDURIT sinks made of Technical Ceramics are the ideal match for FRIDURIT benchtops. They are glazed on the inside and around the edges and are supplied with a 1½" male screw PP outlet and standpipe.

**Options for installation:**

- top-mounted
- flush-mounted

Figure 11)

Internal Dimensions (in mm)			External Dimensions (in mm)			Weight (in kg)	Order Code
l	b	t	L	B	h		
400	400	250	460 <sup>+3</sup>	460 <sup>+3</sup>	273	25	VBES442
500	400	250	560 <sup>+3</sup>	460 <sup>+3</sup>	273	26	VBES542

Please note that FRIDURIT laboratory sinks are only available in plain glaze colours.

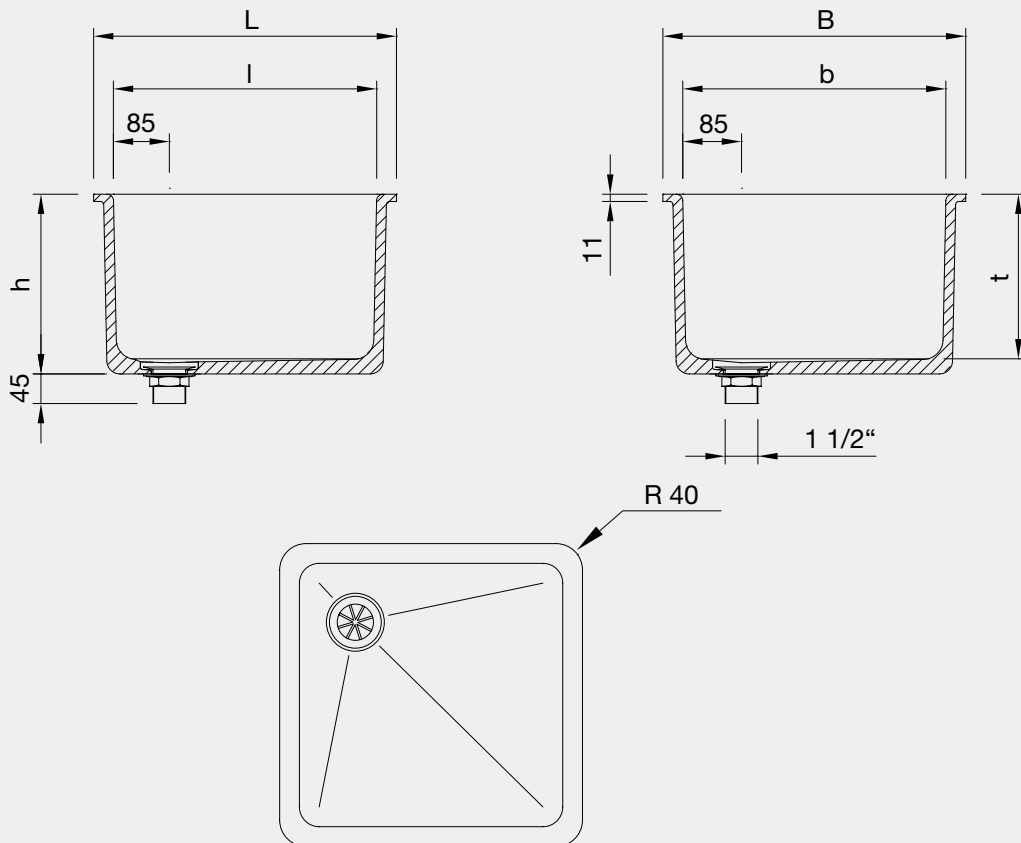

Figure 12)

## Cup Sinks - Oval

FRIDURIT cup sinks made of Technical Ceramics are the ideal match for FRIDURIT benchtops. They are glazed on the inside and around the edges and are supplied with a 1½" male screw PP outlet.

### Options for installation:

- top-mounted
- flush-mounted



Figure 13)

Internal Dimensions (in mm)			External Dimensions (in mm)			Weight (in kg)	Order Code
l	b	t	L	B	h		
250	95	112	294 <sup>±3</sup>	140 <sup>±3</sup>	185	3	VBPE291

Please note that FRIDURIT laboratory sinks are only available in plain glaze colours.

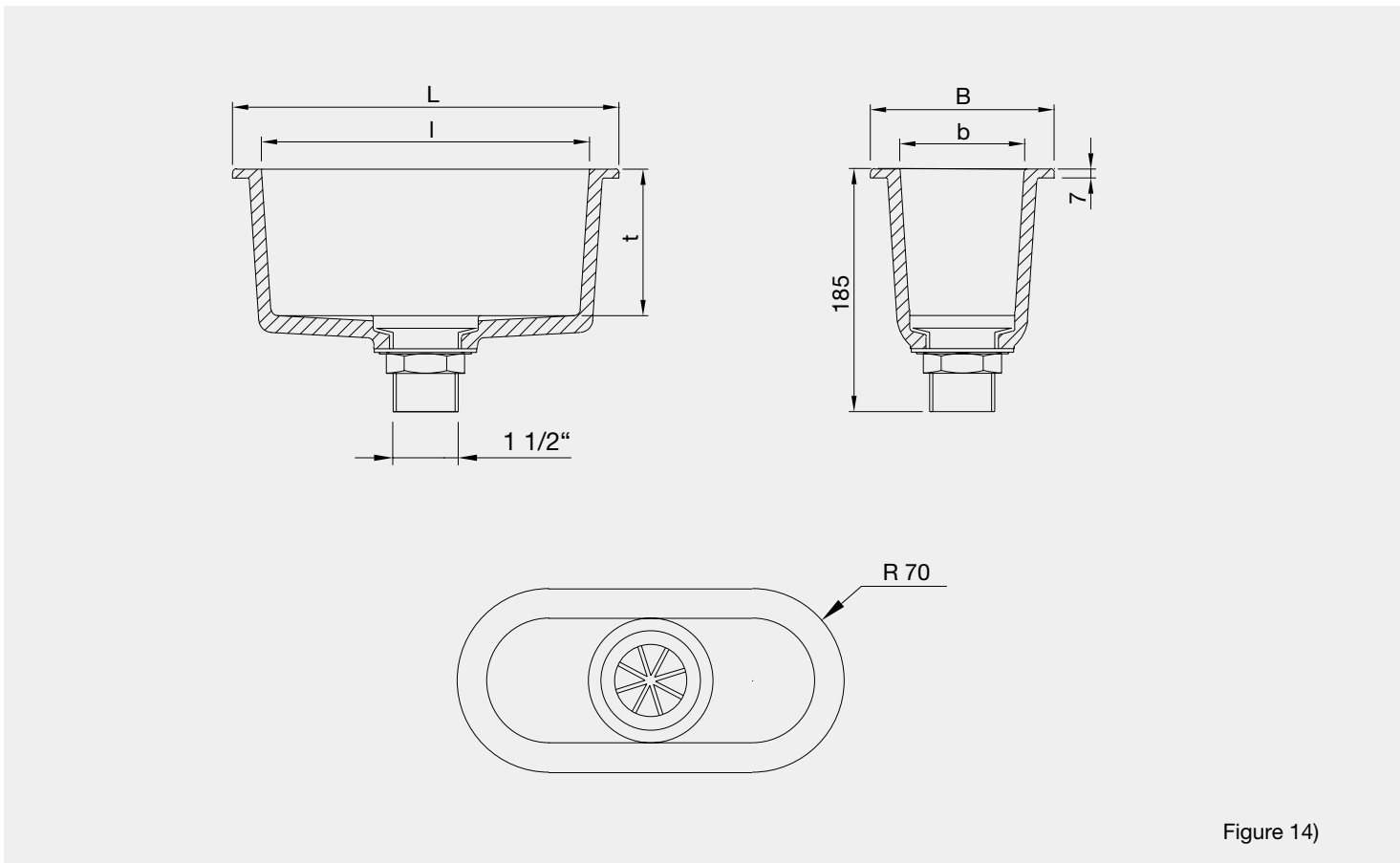
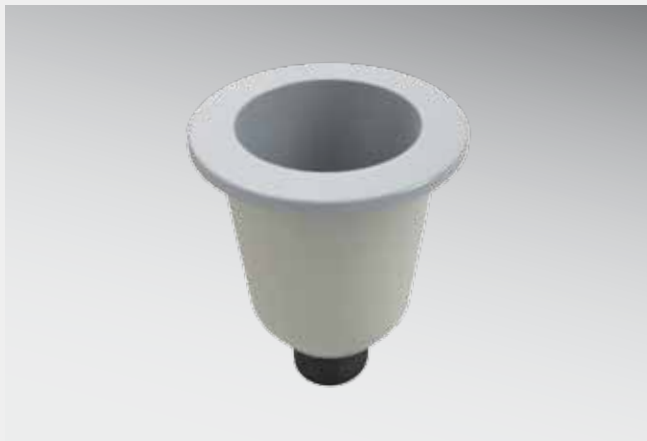

Figure 14)



### Cup Sinks - Round

FRIDURIT cup sinks made of Technical Ceramics are the ideal match for FRIDURIT benchtops. They are glazed on the inside and around the edges and are supplied with a 1½" male screw PP outlet.

**Options for installation:**

- top-mounted
- flush-mounted

Figure 15)

Internal Dimensions (in mm)		External Dimensions (in mm)		Weight (in kg)	Order Code
øI	t	øL	h		
105	112	145 <sup>±3</sup>	185	1,5	VBPE111

Please note that FRIDURIT laboratory sinks are only available in plain glaze colours.

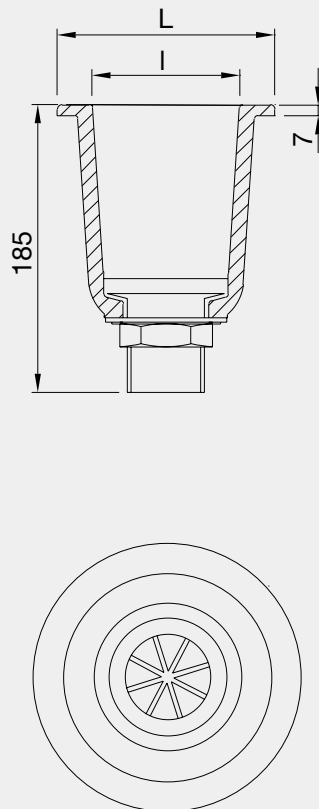

Figure 16)

## P-Trap

A polyethylene P-trap (stench trap) is available for connection to the waste-water pipe, whether horizontal or vertical.



Figure 17)

Description	Order Code
P-trap, horizontal/vertical Outlet: Compression fitting DN50 Connection: 1½" female screw x 100 mm	BZS001

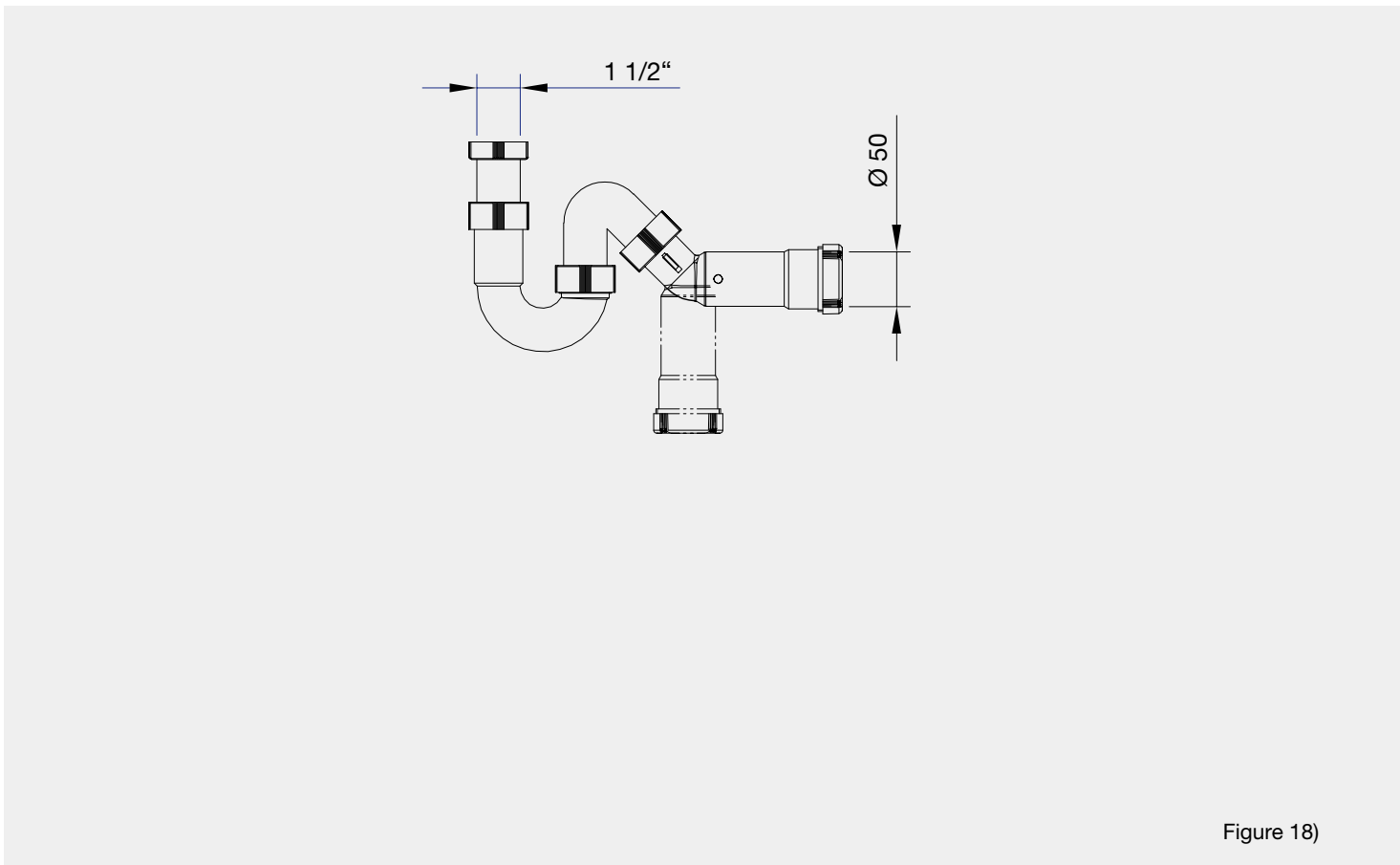

Figure 18)

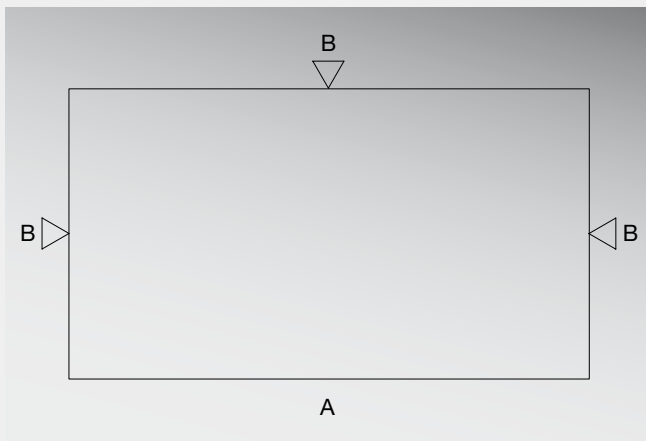

Figure 19)  
Benchtop with 3 cut/unglazed edges, front edge glazed

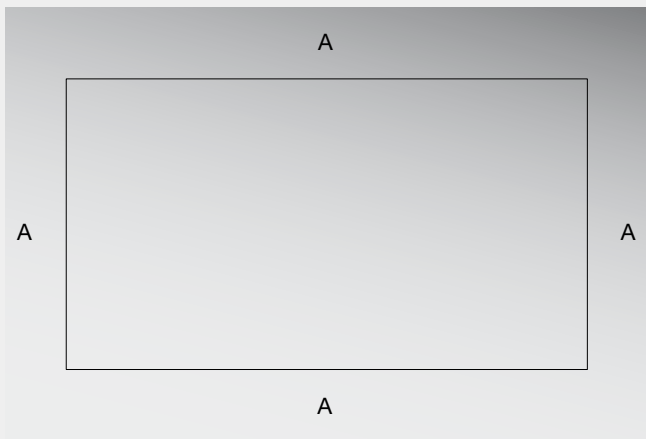

Figure 20)  
Fully glazed benchtop

## Cutting Signs

Depending on the mounting environment FRIDURIT modular benchtops are manufactured with cut (i.e. unglazed) or glazed edges. We recommend a cut edge if it is “hidden”, e.g. when wall-fitted or service spine fitted. Joint edges are always cut. This leads to lower tolerances and ensures a smoother joint.

The edge finish is marked with the following symbols.

▽ = cut, unglazed edge  
(mandatory information)

○ = glazed edge  
(optional information)

During the manufacturing process ceramic benchtops are subject to material-specific shrinkage. Even when using the most advanced manufacturing technologies this cannot always be avoided. The shrinkage range varies from ± 1mm to ± 1%, depending on edge finishing.

The figures on the left show examples of benchtops with glazed and/or cut edges. For better understanding, the edge profiles have been marked with the respective letters (see Chapter on “Edge Profiles”). Indicating the edge profile by means of the symbols for the edge finish is sufficient when ordering.

## Edge Profiles

FRIDURIT modular laboratory benchtops made of Technical Ceramic can be manufactured with glazed edges (edge profile „A“) or with cut edges (edge profile „B“).

## Apertures and Bores

The location of apertures and bores on the worktop can be selected freely while taking account of the minimum distances required by the material. Apertures are always unglazed.

The following principles apply to the required minimum distance to glazed or cut edges:

### Minimum distances for sink apertures:

a: min. 100 mm

### Minimum distances for cup sink apertures:

b: min. 50 mm

Bores are always unglazed and are available in the following standard diameters:

Ø 5 / 8 / 10 / 15 / 20 / 25 / 28 / 30 / 35 / 40 / 50 mm

Other diameters available upon request.

## Edge Cutouts

### The following applies to edge cutouts:

- Edge cutouts are always unglazed
- Minimum corner radius: 12 mm

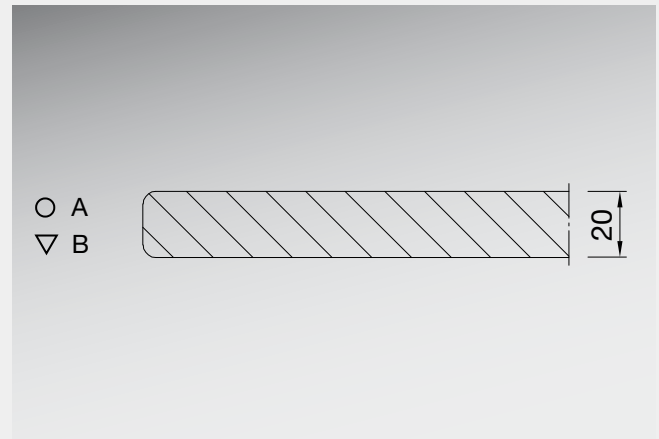

Figure 21)  
Edge profiles

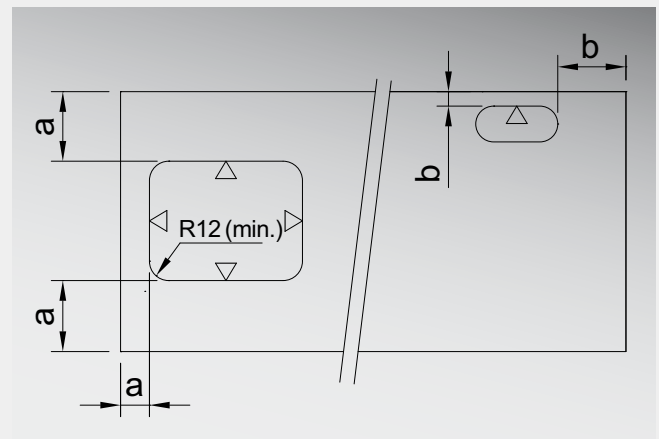

Figure 22)  
Minimum distances for unglazed apertures

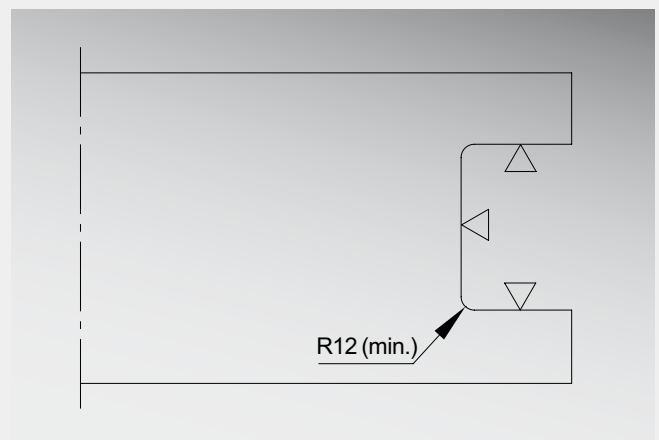

Figure 23)  
Example of a cut edge cutout



Figure 24)  
Mounting benchtops with four-point support on levelling devices



Figure 25)  
Levelling details

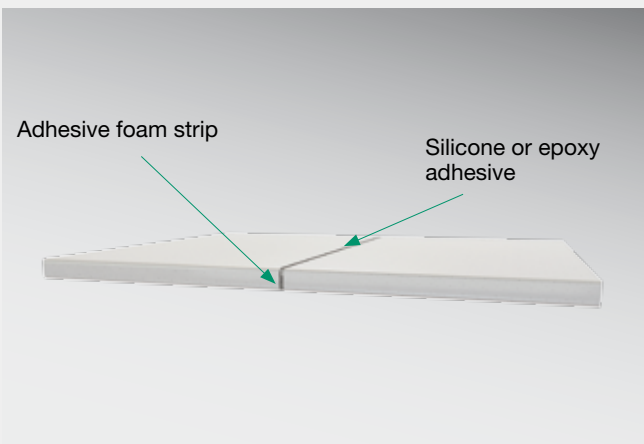

Figure 26)  
Joint details

## Mounting

FRIDURIT laboratory benchtops are provided ready for mounting. Due to their extreme stability, FRIDURIT laboratory benchtops are self-supporting. This means that four-point support is sufficient (see illustration).

The breaking load (P) of the benchtop without cutouts depends on the width (B) and length (L) of the worktop:  
 $P \text{ (in kg)} = 1000 \times B/L \text{ (in mm)}$ .

For swift and easy installation we recommend mounting benchtops on levelling devices (Order Code PZN001).

## Joint Sealing

There are two ways of sealing full-size FRIDURIT laboratory benchtops:

- permanently elastic, using silicone<sup>3</sup>
- hardening using, for example, epoxy sealing material<sup>3</sup>

We generally recommend the use of adhesive foam strip or similar materials as spacers in order to ensure an even joint. Joint width should already be taken into consideration when planning benchtop dimensions.

We will be pleased to send you further instructions containing further details.

## Installation Options

### Top-mounted

Sinks are top-mounted in an aperture (unglazed) of the full-size FRIDURIT laboratory benchtop and then sealed with silicon (see Figure 27)<sup>3</sup>. Uncontrolled leakage of liquid into the waste-water system can thus be prevented.



Figure 27)  
Example of top-mounted sink

### Flush-mounted

Sinks are flush-mounted in the stepped aperture (unglazed) of the full-size FRIDURIT laboratory benchtop and sealed with permanently elastic silicone or by means of hardening (see Figure 28)<sup>3</sup>. The top joint can very easily be cleaned.



Figure 28)  
Example of flush-mounted sink

<sup>3</sup>Please observe the product-specific processing instructions provided by the sealant manufacturer.

## General Product Information

FRIDURIT modular full-size laboratory benchtops and sinks are made of Technical Ceramics (chemical-technical stoneware in accordance with DIN EN 14879-6, Table 5). The superior-quality siliceous material is produced using natural raw materials such as clay, kaolin and feldspar in a special kilning process at temperatures exceeding 1200°C.

## Cleaning

The high density of the material results in easy-to-clean, permanently sealed surfaces that are also virtually joint-free due to the large size of the laboratory benchtops.

We recommend cleaning the FRIDURIT worktops with a sponge or cloth using traditional cleaning agents such as those used in bathrooms. Stubborn dirt on FRIDURIT laboratory benchtops can be removed using an abrasive sponge suitable for glass ceramics. This will not result in any surface scratching.

## Quality Guidelines

Before leaving our factory all our products are subjected to stringent controls in order to ensure the same high standards of quality. Just like wood or leather products, which are much appreciated for their individual grain and texture, FRIDURIT laboratory benchtops made of Technical Ceramics may show optical irregularities.

Natural variations in colour and appearance on the same benchtop and between the various work surfaces are typical of the material and are unavoidable due to the complex manufacturing process. In addition, variations in dimensions, evenness and angularity of the benchtops as a result of material properties may arise.

The features indicated do not affect quality and thus do not constitute any defects. Far more, they belong to the characteristic properties of the material.

We will be pleased to answer any questions you may have.

## Physical properties

Property	Measured value	Norm	Result
Raw density	2.37 g/cm <sup>3</sup>	DIN EN 993-1	
Weight	50 kg/m <sup>2</sup>		
Thermal conductivity	1.57 W/mK	DIN EN 821-2	
Breaking load (P) benchtops in kg	P = 1000 x B/L		
Behaviour in fire	Building material class A1	DIN EN 13501-1, DIN 4102	non-combustible, no thermal load

## Mechanical properties

Property	Measured value	Norm	Result
Cold compression strength	159 MPa	DIN EN 993-5	
Bending strength	41.3 MPa	DIN EN 993-6	
Static modulus of elasticity	39.0 GPa	DIN EN 993-6	
Wear	8.5 cm <sup>3</sup> /50 cm <sup>2</sup>	DIN 52108	
Scratch hardness	7 (Mohs scale)	DIN EN 101	
Crazing resistance		DIN EN ISO 10545-11	no crazing

## Thermal properties

Property	Measured value	Norm	Result
Thermal expansion	$(\alpha_{25-400})$ 5.6 10 <sup>-6</sup> K <sup>-1</sup> $(\alpha_{25-800})$ 5.9 10 <sup>-6</sup> K <sup>-1</sup> $(\alpha_{25-1200})$ 6.3 10 <sup>-6</sup> K <sup>-1</sup>	DIN 51045-2	
Application temperature	up to 550 °C, temporary exposure up to 800 °C		

## Chemical resistance

Property	Description	Norm	Result
<b>Resistance to testing solutions</b> (e.g. solution of hydrochloric acid and sodium hypochloride)	Test samples made of FRIDURIT Technical Ceramics are exposed to testing solutions. The samples are examined visually after a specific period of time.	DIN EN ISO 10545-13	None of the testing solutions affect the test samples.
<b>Resistance to staining</b> (e.g. iodine)		DIN EN ISO 10545-14	Solutions can be completely removed with water.

## Optical properties

Silk finish surface in the current glaze colours. Other colours are available to special order. Colour samples are available on request.

# WORLDWIDE AT YOUR DOORSTEP

---

**FRIATEC Aktiengesellschaft**  
**Ceramics Division**  
Steinzeugstraße 50  
68229 Mannheim, Germany  
Phone: +49 621 486-1879  
Fax: +49 621 486-1605  
info-fridurit@friatec.de  
www.friatec.de



an *Aliaxis* company