



FRIALEN®



Always the right decision:

FRIALEN® **Spigot Saddles**

SA, SA-TL and SAFL:

Drilling of HD-PE pipes – pressure free or under operating pressure



USE FRIALEN® SPIGOT SADDLES TO CONSTRUCT BOTH WITHOUT NO PRESSURE AND UNDER



Picture 1:
Exemplary involvement for the connection to operating pressure pipes using a shut-off device

An additional shut-off device is required for connection under working pressure. FRIALEN® spigot saddles are an economic alternative for the integration of a T-piece into the supply line. Saving potential amounts to up to 50% compared to conventional technology.

Processing and Dimensions

Spigot saddles are assembled as simply and quickly as conventional saddle construction parts using base clamp up to 225, also using the TL top loading procedure with separate FRIATOP Clamping unit up to d 560.

Fusing the FRIALEN® spigot saddles to the HD-PE distributor and the HD-PE domestic mains pipe systems is carried out by the FRIALEN® fusion process - tight and with axial force (see also corresponding FRIALEN® assembly instructions).

For dimensions and drilling diameters, please refer to the table on page 4.

AREA OF APPLICATION

FRIALEN® SA, SA-TL and SAFL spigot saddles are used to create tees on gas, water or sewage pressure pipes.

Fusing and drilling of mains is possible both under no pressure and under the maximum authorised working pressure (see also FRIALEN® data sheets SA, SA-TL and SAFL).



Picture 2:
Direct, pressure free drilling of SA as reduced T-piece using drilling equipment by Hütz + Baumgarten

JECT SAFE PIPE TEES WORKING PRESSURE



Drilling HD-PE pipe systems without pressure (picture 2):

This is carried out using e.g. drilling equipment by Hütz + Baumgarten. Drilling does not involve cutting, and a punch drill up to 46 mm is used (corresponding approx. to the internal diameter $d_{63}/SDR11$). Due to recently developed cutting geometry, larger drilling diameters up to 123 mm at this point in time (corresponding approx. to the internal diameter $d_{160}/SDR11$) can be realised with little force and almost swarf free.

Drilling equipment, where available, may be used or complemented by individual components. A centre drill is not necessary. Please observe operating instructions for each drilling device.

Drilling of pressured HD-PE pipe systems (Pictures 3-5):

Shut-off components are added to above drilling equipment by Hütz + Baumgarten. A shut-off valve made of PE e.g. FRIALOC or a ball valve e.g. FRIALEN® KHP may be applied. A temporary barrier in the low pressure range can be achieved by gas pockets using FRIALEN® SPA shut off saddles.

The drilling equipment can be attached using

- flange, e.g. FRIALEN® EFL full faced flange (picture 3), SAFL
- PE spigot saddles fixture (pictures 2+4)
- AQUAFAST®, a draft proof clamp flange, reusable due to the fact that it can be disassembled (picture 5).

After disassembling the AQUAFAST® clamp flange or clamping fixture, the pipe tee can be carried on in the conventional way using FRIALEN® UB/MB couplers. You will find current Data Sheets of the individual components under www.friatec.de.



Picture 3: Drilling via standard flange, valve and SAFL



Picture 4: Drilling via clamping fixture and ball valve



Picture 5: Drilling via AQUAFAST® clamp flange and FRIALEN® SPA shut off saddles with setting device

MOULDED PARTS AND EQUIPMENT ARE PERFECTLY CO-ORDINATED:

Drilling device and drilling diameter (in mm)

d ₁ Tee diameter Ø main pipe- measurements	d ₂ external diameter SA/SA-TL outlets								
	d 32	d 50	d 63	d 90	d 110	d 125	d 160	DN 80	DN 100
Hütz + Baumgarten ¹⁾ PE drilling system	drilling diameters d ₃								
SA d 63	20	36	-	-	-	-	-	-	-
SA d 75	-	36	-	-	-	-	-	-	-
SA d 90	20	-	46	-	-	-	-	-	-
SA d 110	20	36	46	65	-	-	-	-	-
SA d 125	20	-	46	65	84	-	-	-	-
SA d 160	20	-	46	65	84	95	-	-	-
SA d 180	-	-	46	65	84	95	-	-	-
SA d 200	-	-	46	-	-	-	-	-	-
SA d 225	-	-	46	65	84	95	123	-	-
SA-TL d 250-560 ²⁾	20	-	46	60	-	-	-	-	-
AKHP/AKHP-TL ^{2) 3)}	-	-	42	60	-	-	-	-	-
SAFL ⁴⁾	-	-	-	-	-	-	-	65	84
FRIALOC®	-	-	-	65	84	84	123	-	-

1) Hütz + Baumgarten GmbH & Co. KG
Anbohrgeräte
Solinger Straße 23-25
D-42857 Remscheid
Phone +49 2191/9700-0
Fax +49 2191/9700-44
www.huetz-baumgarten.de
info@huetz-baumgarten.de

2) FRIATOP Clamping unit required for TL variants

3) 4) See also FRIALEN®-datasheets ball valve, spigot saddles



Picture 6: Drilling equipment

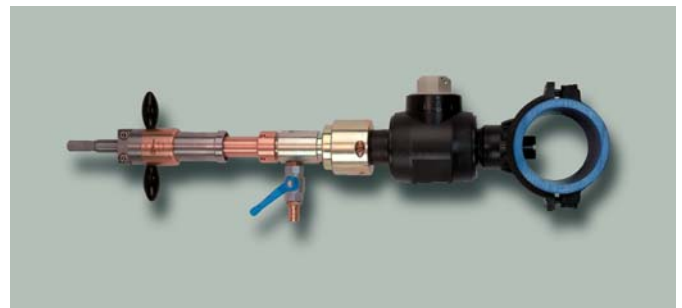

Picture 7: Drilling via AKHP

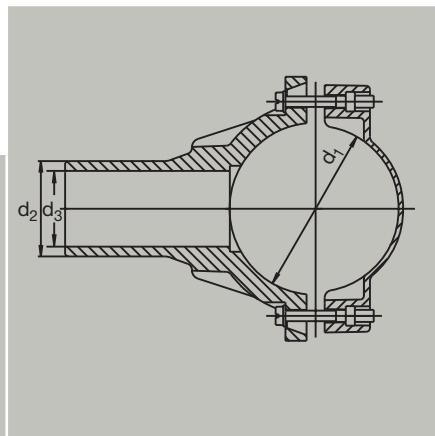

Picture 8:
Spigot Saddle SA

For further information, please call our **FRIALEN®** customer service staff and specialist advisers.

FRIATEC Aktiengesellschaft · Technical Plastics Division
P.O.B. 71 02 61 · D-68222 Mannheim
Telephone +49 621 486-0 · Telefax +49 621 479196
www.frialen.com · E-Mail: info-frialen@friatec.de

FRIATEC
an OAliaxis company